



Features

- 800 Watts Peak Pulse Power per Line ($t_p = 8/20\mu s$)
- Unidirectional Configuration
- Protects One Power or I/O Port
- Low Clamping Voltages
- Ultra Low Capacitance: 1.0 pF Typical

IEC COMPATIBILITY (EN61000-4)

- IEC 61000-4-2 (ESD) $\pm 15kV$ (air), $\pm 8kV$ (contact)
- IEC 61000-4-4 (EFT) 40A (5/50ns)
- IEC 61000-4-5(Lighting) 20A (8/20 μs)



Mechanical Characteristics

- Molded JEDEC SOD-323 package
- Weight 10 milligrams (Approximate)
- Flammability rating UL 94V-0
- 8mm Tape and Reel Per EIA Standard 481
- Device Marking: Marking Code
- RoHS Compliant

Applications

- Ethernet - 10/100/1000 Base T
- Cellular Phones
- Handheld - Wireless Systems
- Personal Digital Assistant (PDA)
- USB Interface

PIN Configuration

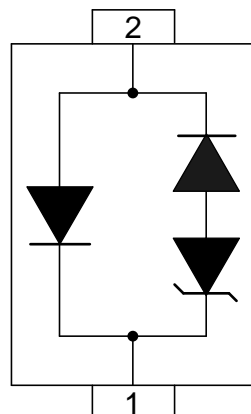

UNIDIRECTIONAL

Absolute Maximum Rating

Rating	Symbol	Value	Units
Peak Pulse Power ($t_p=8/20\mu s$) - See Figure 1	P_{PP}	800	Watts
Operating Temperature	T_J	-55 to +125	°C
Storage Temperature	T_{STG}	-55 to +150	°C

Electrical Parameters ($T=25^\circ C$)

Symbol	Parameter
I_{PP}	Reverse Peak Pulse Current
V_C	Clamping Voltage @ I_{PP}
V_{RWM}	Working Peak Reverse Voltage
I_R	Reverse Leakage Current @ V_{RWM}
V_{BR}	Breakdown Voltage @ I_T
I_T	Test Current
I_F	Forward Current
V_F	Forward Voltage @ I_F

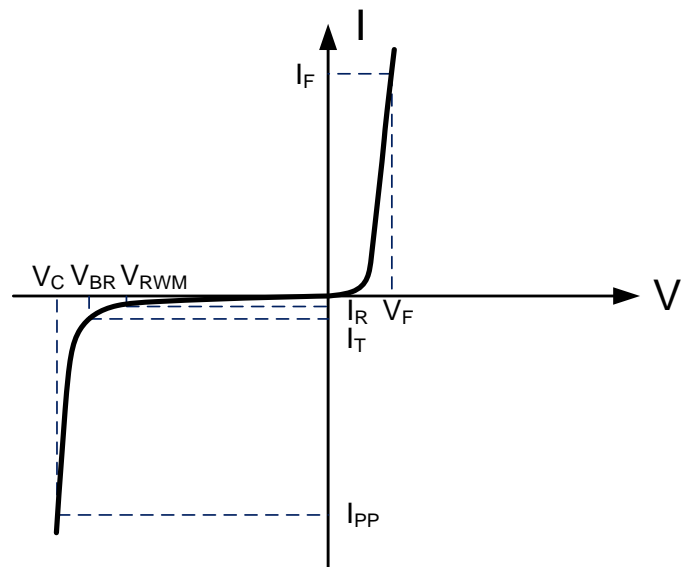

Electrical characteristics

PART NUMBER (See Note 1 & Note 2)	RATED STAND-OFF VOLTAGE V_{WM} (Volts)	MINIMUM BREAKDOWN VOLTAGE @ 1mA V_{BR} (Volts)	MAXIMUM CLAMPING VOLTAGE (See Fig. 2) @ IPP = 1A V_C (Volts)	MAXIMUM CLAMPING VOLTAGE (See Fig. 2) @8/20 μs V_C @ IPP	MAXIMUM LEAKAGE CURRENT @ V_{WM} I_d (μA)	TYPICAL CAPACITANCE @0V, 1 MHz C(pF)
DW05DLC-S	5.0	6.0	9.8	30V @ 20.0A	1	1

Typical Characteristics

Figure 1: Peak Pulse Power vs. Pulse Time

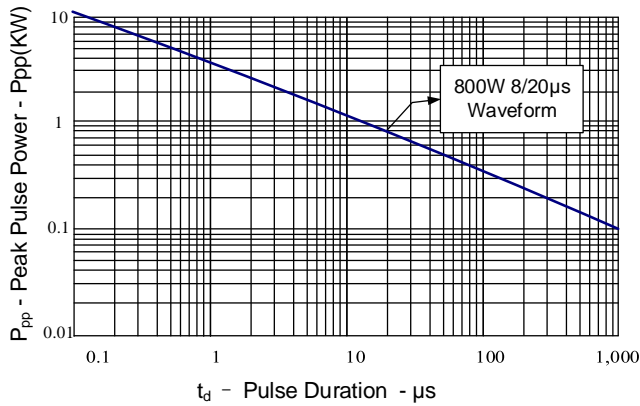

Figure 2: Power Derating Curve

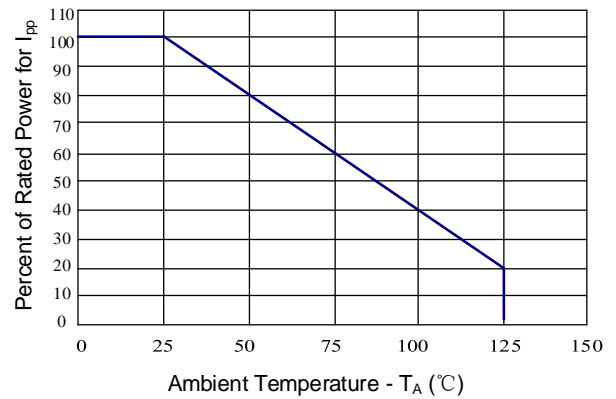

Figure 3: Clamping Voltage vs. Peak Pulse Current

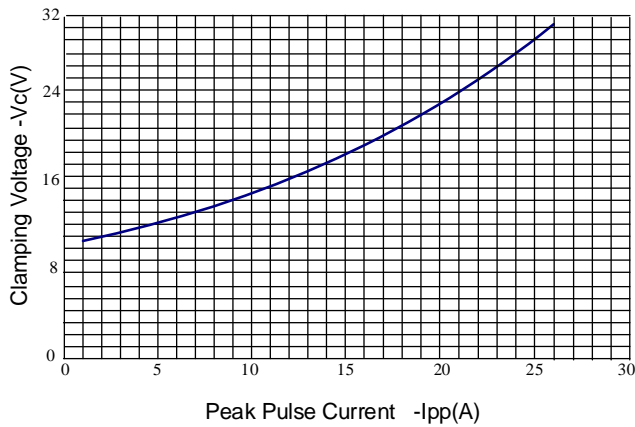

Figure 4: Normalized Junction Capacitance vs. Reverse Voltage

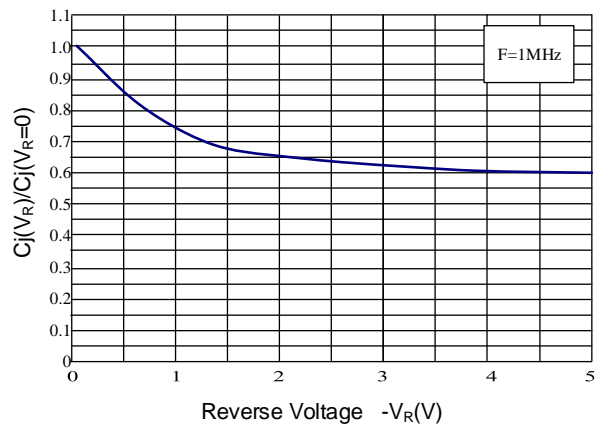

Figure 5: Pulse Waveform

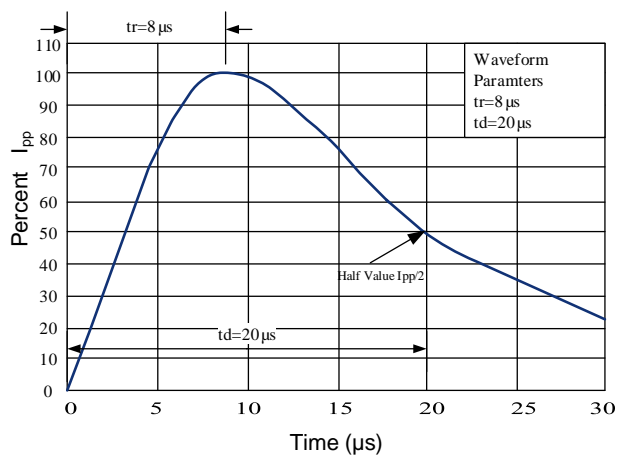
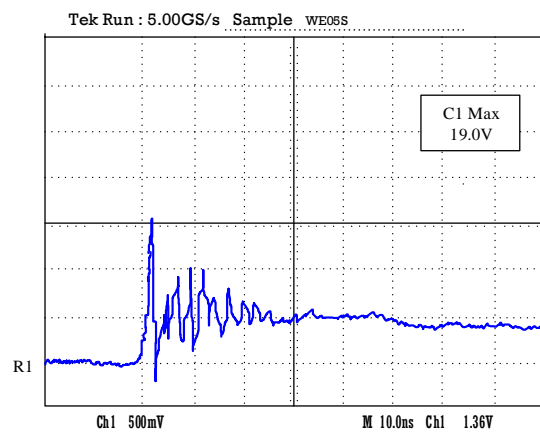
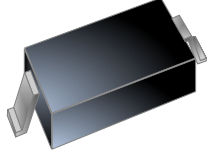
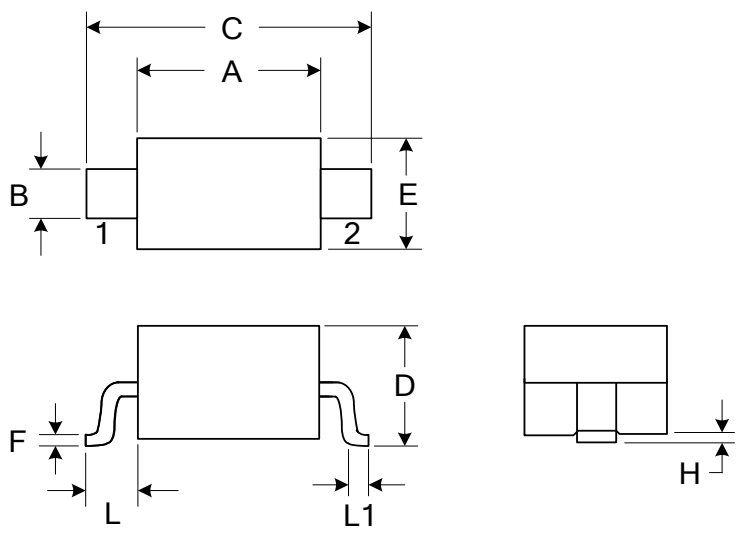
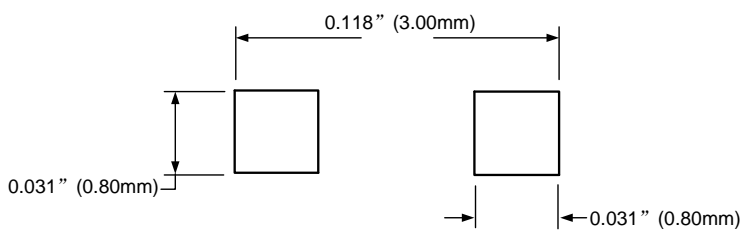

Figure 6: ESD Clamping(8kV Contact per IEC 61000-4-2)



Outline Drawing – SOD-323

PACKAGE OUTLINE		 SOD-323			
		DIMENSIONS			
SYMBOL	MILLIMETER		INCHES		
	MIN	MAX	MIN	MAX	
A	1.60	1.80	0.063	0.071	
B	0.25	0.35	0.010	0.014	
C	2.50	2.70	0.098	0.106	
D	0.00	1.00	0.000	0.039	
E	1.20	1.40	0.047	0.055	
F	0.08	0.15	0.003	0.006	
L	0.475 REF		0.019REF		
L1	0.25	0.40	0.010	0.016	
H	0.00	0.10	0.000	0.004	
MOUNTING PAD		Notes 1. Controlling Dimensions in Millimeters. 2. Dimensions are exclusive of mold flash and metal burrs.			
					

Marking Codes

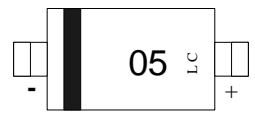
Part Number	DW05DLC-S
Marking Code	

Package Information

Qty: 3k/Reel